



# Assembly Machines



## Alfing – 3 strong companies. With over 100 years of experience.

Karl Kessler founded Maschinenfabrik Alfing Kessler GmbH (MAFA) in 1911. Today it is the largest global manufacturer of crankshafts for automotive and large engines, as well as induction hardening systems. Alfing crankshafts can be found in large ship engines and in Formula 1 race cars.

Alfing Kessler Sondermaschinen GmbH (AKS) was opened in 1938. Today's portfolio encompasses the three areas of transfer lines, machining centers, and fracture systems. Its areas of expertise are the machining of con rods and aluminum parts.

In 1981 the third member of the Alfing family was formed: Alfing Montagetechnik GmbH (AMT). It operates in the market sectors of nutrunner technology, assembly machines, and automation.

Since 1992 Alfing has been represented in the USA with a sales and service division. We employ over 2,000 people worldwide.



Automotive Crankshafts  
Large Crankshafts  
Hardening Systems

**ALFING**  
ALFING KESSLER SONDERMASCHINEN

Transfer Lines  
Machining Centers  
Fracture Systems

**AMT**

Nutrunner Technology  
Assembly Machines  
Automation

# Custom Assembly Machines

AMT provides customized, cost-effective solutions, tailored to the assembly task at hand, production environment, and economic requirements. In doing so, we combine tried and true modules and integrate them into an efficient assembly process. New solutions can also be developed for you, based on need.



**Feed**



**Preparation**

## Feed

## Preparation

Feed  
Separate  
Orient  
Check

Feed Devices  
Pallet Systems  
Gantry Loaders  
Robots

Cool  
Heat  
Lube  
Wet  
Mark

Nitrogen Conveyors  
Warming Ovens  
Roto-Spray  
Embossing/Scribing Units  
Laser



**Assembly**



**Check**

# Assembly Check

Position  
Plug  
Fasten  
Press In  
Press On  
Run Down  
Join

Multi-Axis Devices  
Robots  
Gantries  
Nutrunners  
Press Spindles

Monitor Torque and Angle  
Measure Force and Distance  
Check Geometry  
Check Position  
Measure Flow  
Leak-Test

Nutrunner Controls  
Press Controls  
Monitor Flow  
Measuring Sensors  
Check Leads  
Leak-Test Device

**AMT**

# Innovation, Experience, Reliability

## AMT – Partner to the Automobile Industry

- AMT has more than 25 years of experience in planning, developing, and manufacturing assembly machines for the total powertrain spectrum, from passenger cars to commercial trucks. Several notable automotive manufacturers and suppliers belong to our customer base.

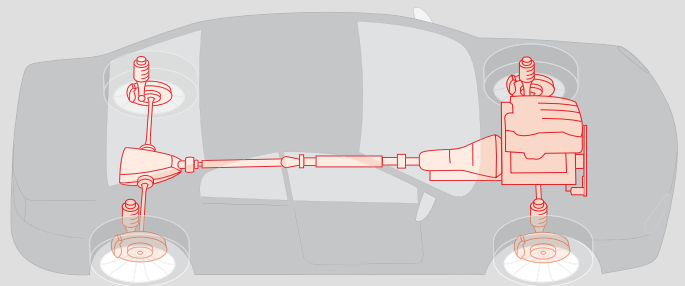

Engines, cylinder heads, and transmission and axis components are assembled throughout the world on our assembly machines. We are world leaders in the areas of cylinder head and engine block assembly.

In order to properly address the increased efficiency and quality demands from our customers, we are continuously looking for new automation methods. One example of this is our patented process for joining cylinder liners. Another example is the development of our assembly

centers, which set the standards for flexibility and reliability. All AMT machines stand out with their solid construction – the basis for precision assembly processes. From the machine base to the smallest electronic component, we guarantee the highest quality throughout.

Whether it's a manual work station or a fully automated assembly line: AMT brings solutions to life that can be optimally integrated into your production environment, as well as meet your cost-saving requirements.

# Technology for Mass Production

## Flexible and Productive

- AMT provides turnkey assembly systems, which have been adapted to individual customer requirements. Is production capacity your focus point? Should different part types be assembled on the same system? Are you planning a gradual increase in production? – AMT always has the right solution



Modern production techniques demand a high flexibility in regard to the parts being assembled, while simultaneously providing high system availability. The flexible assembly machines that we develop meet both of these criteria.

The use of assembly modules enables hybrid system structures. The use of multi-axis NC tables or robots in the assembly modules provides the desired flexibility.

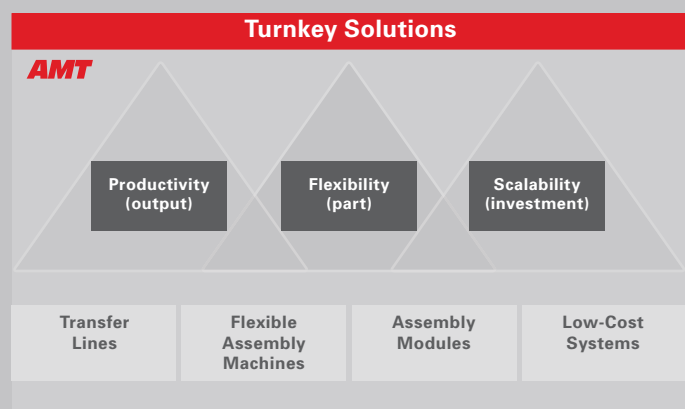



## Cylinder Head

- Press in valve seat rings and guides with or without nitrogen super cooling
- Camshaft assembly
- Feed and fastening of bearing caps
- Stud bolt assembly
- Fastener assembly (balls, covers, KOENIG expander)

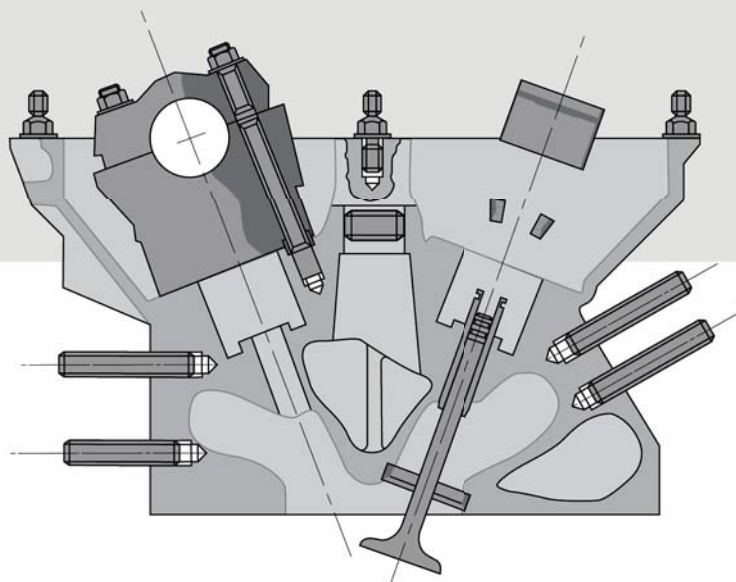

Controlled pressing of valve seat rings with electric press spindles

Feed Position Lube Plug Fasten Press In Check Mark



## Engine Block

We develop individual supply and feed strategies for your assembly parts. Dependent upon the available work area and the sensitivity of the assembly parts, feed devices or pallet systems come into operation.

- Crankshaft assembly
- Feed and fastening of bearing caps
- Assembly of sealing parts
- Leak-test

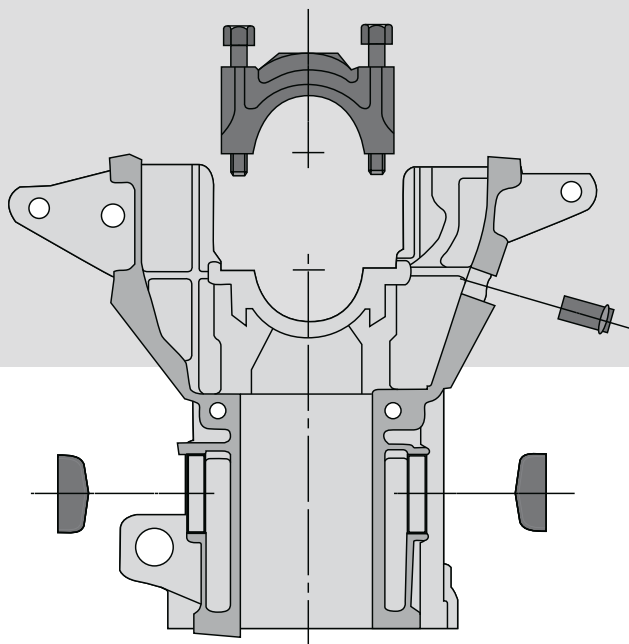

Short cycle time with high flexibility: dual nutrunner with adjusting device

Feed Position Lube Plug Fasten Press In Check Mark



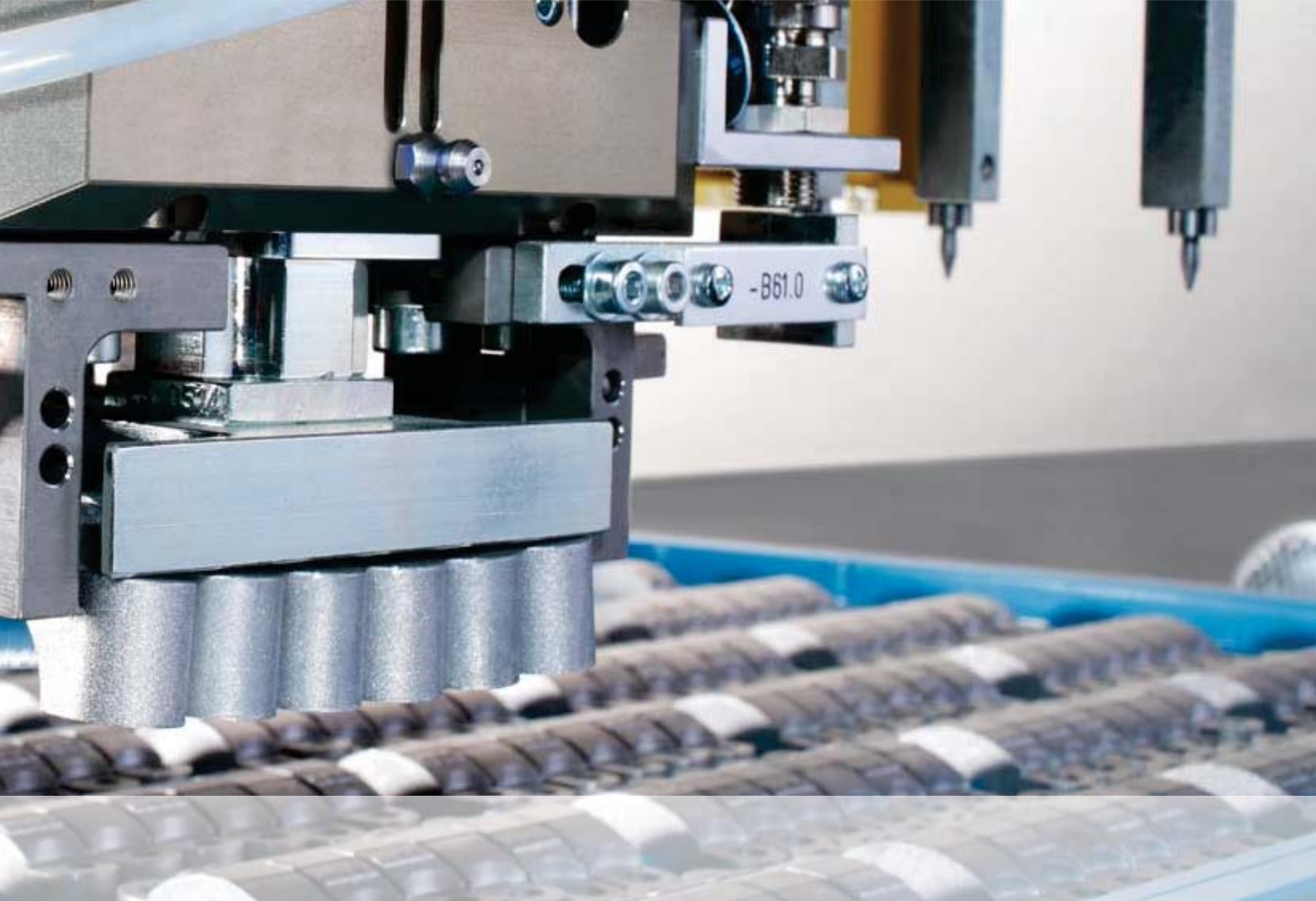

## Leak-Test

The leak-test station can either be directly integrated in the assembly machine or configured as a separate station.

Tested:

- Water chamber
- Pressurized oil chamber
- Non-pressurized oil chamber

Leak-test devices according to customer specifications are implemented.

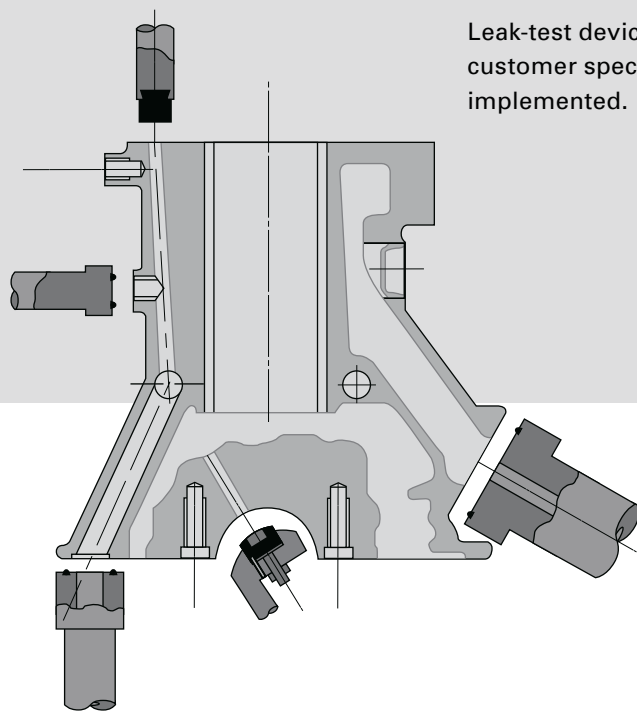

Force fit sealing parts and leak-test

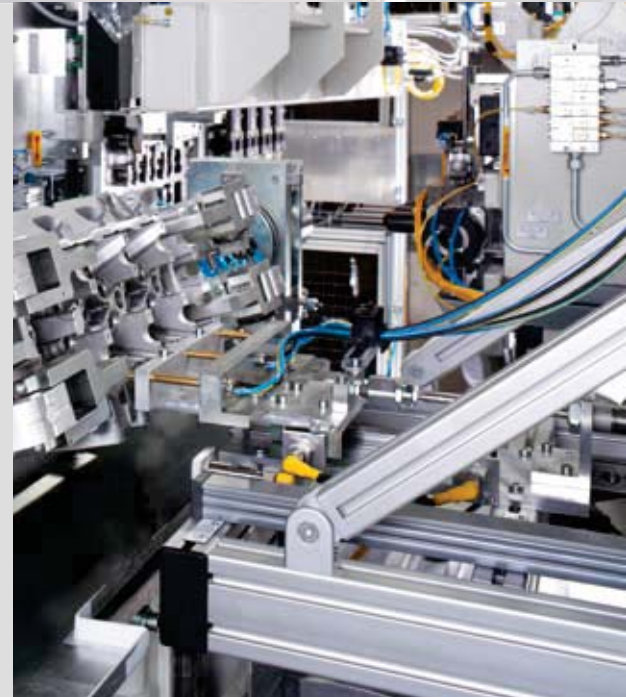
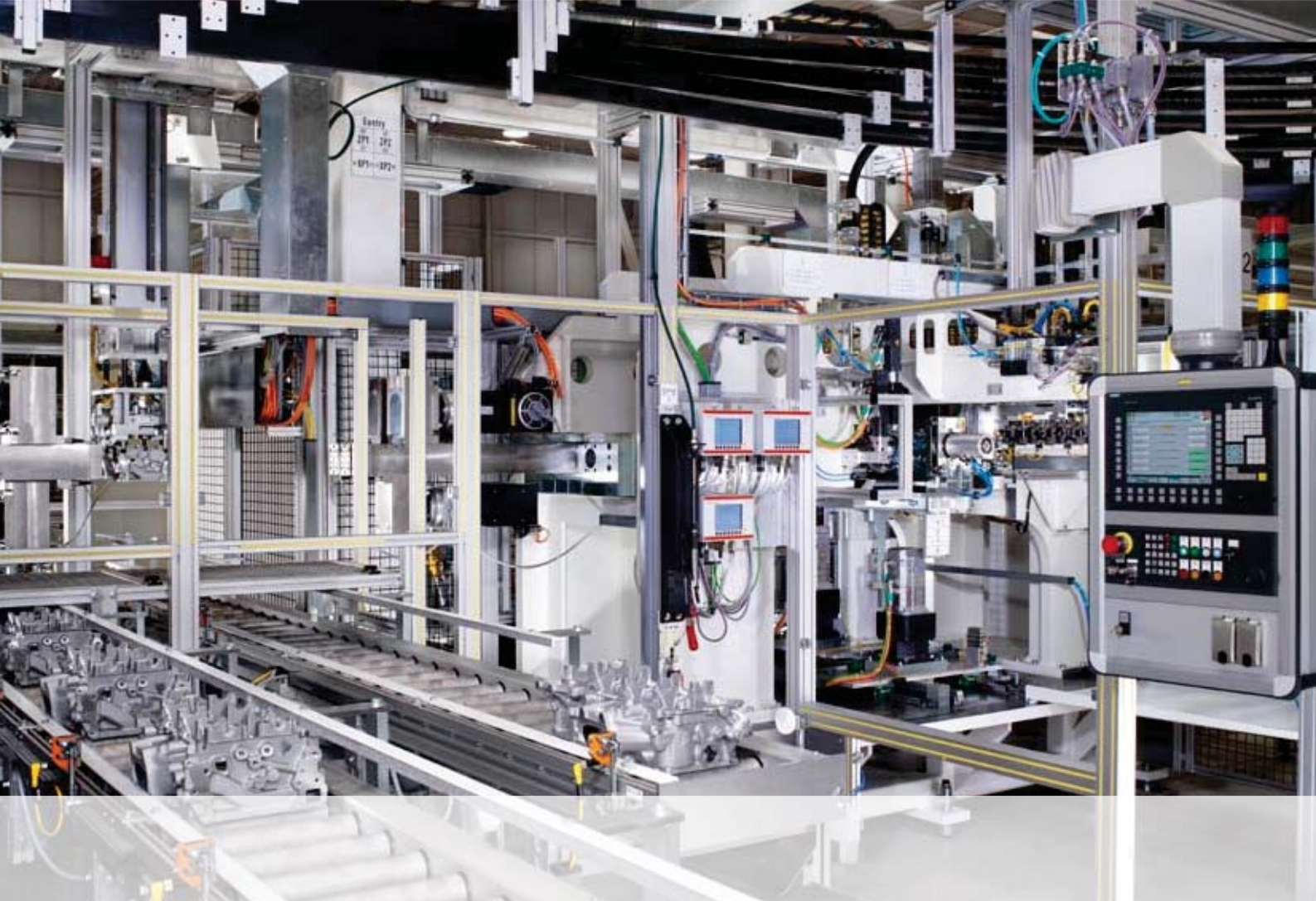

# Professional Project Management

## Achieve mutual goals

- You can rely on us to carry out complex projects for you. We take care of your needs with our professional project management team: from concept design to engineering to startup and after-sales service.



Our consultants will support you starting at the concept phase. During the simultaneous engineering phase of the project, assembly processes are analyzed, designed, and optimized in close cooperation with you.

Each project is handled from start to finish by one of our experienced project managers. He is responsible for a smooth and timely execution. A team of experienced colleagues from engineering and assembly are assigned to him.

During the implementation phase, we make sure, with your help, that all requirements from your operator and maintenance crews have been met. Our mechanical and electrical engineering specialists stand by your side, offering their vast experience with customers from all over the world.

**A professional and experienced team – the basis for our success!**

# Our All-Around Worry-Free Package

## To keep the line running

- AMT service focuses on fast response times and non-bureaucratic assistance. Should your system be down, we are quick to make it operational again. We are there for you: either by telephone through our Service-Hotline or by our on-site field service engineers. Thanks to our efficient inventory and shipping logistics, you receive all required spare parts on short notice.



Our engineers are not only developing new machines for you. They will also support you for retools, overhauls, and as overall service providers during extensive planning tasks.

Our service team will guide you from startup throughout the life of the machine. We offer on-site training on the machine or in our well-equipped training classrooms – designed to meet your requirements.

We serve our customers in Germany and neighboring European countries from our headquarters in Aalen/ Baden-Württemberg. We have our own service support point for England.

We support the US and Mexican markets from Alfing Corporation, our sister company in Plymouth, Michigan.





**Alfing Montagetechnik GmbH**

Auguste-Kessler-Straße 20  
73433 Aalen, Germany  
Phone +49 7361 501-2701  
Fax +49 7361 501-2709  
info@amt.alfing.de  
www.alfing.de

**AMT UK Service**

PO Box 7097  
Leicester, LE3 2QT  
United Kingdom  
Phone +44 7768 925 474  
Fax +44 116 829 3536

**Alfing Corporation**

44160 Plymouth Oaks Blvd.  
Plymouth, MI 48170  
USA  
Phone +1 734 414 5884  
Fax +1 734 414 5899  
www.alfing.com

